













USER MANUAL







DISCO/DISCO P25

DISCO MEDI/DISCO MEDI P25



TABLE OF CONTENTS

1	Foreword:.....	4
2	Warnings.....	6
3	Introductory information:.....	8
3.1	Use.....	8
3.2	Accessibility.....	8
3.3	Adjustments.....	8
3.4	Equipment.....	8
3.5	Transportation  	8
3.6	Cleaning and maintenance.....	8
3.7	Auxiliary electric motor  	9
3.8	Technical specifications.....	9
4	Before using the bicycle for the first time:.....	10
4.1	Statutory provisions.....	10
4.2	Preparing the bicycle.....	10
5	Riding your PF bicycle.....	11
5.1	Riding instructions.....	11
5.2	Before taking your bicycle out for a ride.....	12
6	Safety instructions.....	12
6.1	Wear and tear of wheels and tyres.....	12
6.2	Warnings.....	12
7	Settings and adjustment:.....	13
7.1	Handlebars:.....	13
7.2	Seat:.....	13
7.3	Brakes.....	13
7.4	Gear.....	14
7.5	Chain adjustment.....	15
8	Electrical system and motor  	16
8.1	Electric bicycle and the concept “pedelec”?.....	16
8.2	Safety instruction  	17
8.3	Hazards for special user groups.....	17
8.4	Battery  	17
8.5	Charging the battery  	19

9	Accessories.....	21
10	Maintaining your bicycle	23
10.1	Important  	23
10.2	Daily check.....	23
10.3	Cleaning  	25
10.4	Lubrication	25
10.5	Tightening of bolts, etc.....	25
10.6	Repair and replacement.....	26
11	Disposal  	26
12	Warranty and obligations	26
14.	Manufacturer’s battery handling instructions.....	27
15.	DISPLAY NAVIGATION	32

1 FOREWORD:

Congratulations on your new PF bicycle. We hope that you will enjoy riding it for many years to come! Please read carefully this User and Operating Manual. To be able to take maximum advantage of your bicycle, it is important that you adjust it properly and that you follow the advice we have for you in this User and Operating Manual.

Any serious incident that occurs in connection with the bicycle should be reported to PF Mobility and the local Medicines Agency.

We recommend that you use the bicycle in consultation with your doctor.

Riding your PF bicycle

- **IMPORTANT:** For safety reasons, it is important that the bicycle be serviced at all times by a person with professional training and insight into bicycle technology and function.
- Take particular note of Section 10 *Maintaining your bicycle* – **and remember that maintenance of the electrical system (on bicycles so equipped) may only be carried out by a professional.**
- Always check that the battery is charged before setting off to ensure there is enough power for the journey home. Pls. also see the “Take me home” feature described in the last chapter.

PF mobility has an extensive range of accessories that can contribute to improving the use and experience of your PF bicycle. Our accessories are listed on our website, but a selection of them is also presented under Section 9 *Accessories*.

If you have any further questions about the use of your PF bicycle or this Manual, you are more than welcome to contact us at:



PF mobility ApS
Bjerregårdvej 15, Timring
DK – 7480 Vildbjerg
Tel.: +45 99 92 06 00
Fax: +45 99 92 06 05

Mail: info@pfmobility.dk
www.pfmobility.dk

With reservations for misprints and changes to this User Manual.



2 WARNINGS

- For safety reasons, it is important that the bicycle is continuously serviced by a qualified professional with knowledge of the technology and function of the bicycle.
- Use the parking brake in order to get on and off of the bicycle in a safe manner.
- Brakes should be adjusted regularly – preferably by means of a professional.
- Defect wheel rims can cause accidents and must therefore be replaced immediately.
- Before cycling, loose clothing should be changed to snug-fitting clothing that will not get trapped in rotating parts such as wheels and chains. If the bicycle is equipped with a lap belt that is not in use, it should be ensured that this is unable to get caught in rotating parts.
- Do not use the bicycle if safety guards such as a mudguard, chain guard or guard above the rear axle are defect or missing.
- Inattentiveness when adjusting the seat or armrest can result in a risk of your fingers getting caught.
- Adjustments should only be made when the bicycle is at a standstill.
- A special spacer/extension pipe should be used for adjusting the seat height if this is necessary.
- Never use a high-pressure washer or water jet when cleaning the bicycle.

Specifically for bicycles equipped with batteries and motor systems:

- Always remove the battery from the bicycle when performing maintenance tasks. The motor may be activated unintentionally and set the bike in motion if the electrical system is switched on.
- Any unusual noise as well as unintended reactions from the engine system may indicate a defect. If you experience this, contact the dealer immediately.
- Fire hazard: faulty/broken electrical connections, cables or mechanical damage to the battery can lead to short circuits and must be replaced.
- Fire hazard: The battery may only be charged by means of the matching charger.
- Risk of electric shock: faulty wiring or plugs could result in electrical shock and must be replaced immediately.
- Risk of electric shock: The battery charger must be protected against the ingress of water and moisture.

3 INTRODUCTORY INFORMATION:

3.1 Use

Your PF bicycle has been designed for people with functional disabilities – whether physical or mental.

These include problems with balance in the muscular system, etc.

The bicycle is designed for use on the common public roads and bicycle paths. Always ride the bicycle on an even solid surface and adapt your speed to the conditions at hand. Comply with the provisions of the Road Traffic Act. PF mobility may not be held liable for accidents resulting from improper use or for damage resulting from lack of maintenance.

3.2 Accessibility

We recommend that people with cognitive functional disabilities, visual impairments or reading disabilities, who cannot read and understand this Manual, turn to the dealer where they bought their PF bicycle. The dealer will review the manual and reply to any questions they may have.



3.3 Adjustments

To benefit fully from your new PF bicycle, we ask you to carefully peruse this Manual. Take note of the sections regarding settings and adjustments. Your dealer will help you with any questions about specific settings. Even if the bicycle is made of quality components, it still needs maintenance. You can easily make many of the minor adjustments yourself. This will both extend the service life of the bicycle and make the bicycle ride true enjoyment.

3.4 Equipment

There is a large range of accessories designed for your bicycle. See Section 9 regarding accessories or visit our website.

3.5 Transportation

Fasten the bicycle securely if you need to transport it in a car or in a trailer. When you use hose clamps and similar, make sure that they do not jam any chains, wires and cables. During transportation, your bicycle may be exposed to moisture, dirt and other aggressive substances. This can affect the electrical system, which is why you must cover the bicycle with plastic or tarpaulin when you transport it in an open trailer.

During transportation in a car or trailer:



- Remove the battery and store it in a cool and dry place.
- In humid weather, protect the bicycle by covering it with plastic or tarpaulin.



Note: Do NOT ship the Li-Ion battery as an ordinary package. Li-Ion batteries are considered hazardous goods and should be marked in accordance with the instructions in the ADR convention (UN3840).



3.6 Cleaning and maintenance

Your bicycle needs day-to-day maintenance.

We recommend that you have an annual maintenance check performed by a bicycle professional or PF mobility. Be especially aware of noises and vibrations, which are clear indications that the bicycle is in need of servicing and maintenance.







A review of maintenance checkpoints and methods of cleaning is available under Section 10.

3.7 Auxiliary electric motor

For bicycles equipped with an electric motor, kindly refer to the *E-Bike and Pedelec* section. Sections containing important information for you as an owner of an e-bike are marked in the heading with  

These sections contain warnings you should have a special focus on. Make sure you abide by these.

The following symbols are used in this Manual:

 	<p>Warning: This symbol warns about a hazard to your health and points at a potential risk of injuries.</p>
 	<p>Note: Indicates possible material damage</p>
 	<p>Important: Contains general instructions for safe use and special technical features or directions.</p>
	<p>Information: This symbol refers to tips or special information.</p>

3.8 Technical specifications

Model	DISCO	DISCO MEDI
Data		
Lenght cm	185	171
Width cm	75	68
Weight (w/o accessories)	Ca. 44	Ca. 29
Extra weight E-Bike/ Pedelec	Ca. 11	Ca. 11
Maximum user weight kg	125	125
Maximum load	150	150
Mounting/Dismounting height cm	26	25
Wheel size "	20	16
Max speed motor km/h E-bike / Pedelec	25 km/h	25 km/h

EPAC and Pedelec models

Controller		
Operating voltage		36V
Motor		
Motor output		250W
Battery		
Type		Lithium-Ion battery
Nominal voltage		36 V
Capacity		11 Ah, 396 Wh (standard) 19,2 Ah, 692 Wh (option)
Charging period (fully emptied battery)		Approx. 6 hours at charging current of 2 A (standard bat.) Approx. 9.5 hours at charging current of 2 A (optional battery)
Temperature limitations	Normal operation	-10 to 45 °C
	Charging	10 to 35 °C
	Storage	-10 to 45 °C

4 BEFORE USING THE BICYCLE FOR THE FIRST TIME:

4.1 Statutory provisions

The bicycle is equipped from the factory with statutory equipment pursuant to the Danish Executive Order regarding Design and Equipment, etc. of Bicycles:

We recommend that the bicycle is always fitted with lights as per the applicable legislation. Consult PF mobility or your dealer.

Even if riding with a bicycle helmet is not compulsory by law, we strongly recommend that you always wear a helmet.

It is your responsibility to make sure that defective parts are replaced so that the bicycle remains in lawful condition and thereby safe to ride at all times. PF mobility recommends that you only use original spare parts that ensure that the bicycle meets the applicable legislation.

4.2 Preparing the bicycle

The bicycle is delivered assembled from the factory. If the bicycle has been received from a carrier/forwarding agent, it may be necessary to adjust and fasten properly the handlebars and the seat. See Section 3.3 *Adjustments*.

If your bicycle has been delivered by a consultant from PF mobility, they will review all necessary adjustments together with you. You are subsequently always welcome to contact your dealer or PF mobility for any additional help or instructions.

5 RIDING YOUR PF BICYCLE

To get as much riding joy and benefit as much as possible from your PF bicycle for many years, it is important that you use the bicycle properly.



You can ride the bicycle on different surfaces. PF mobility recommends that you ride on even solid surfaces (preferably asphalt or slabs).

The bicycle is not designed for riding in rough terrain or on a soft surface as this can overload the structure and the frame or the electrical system.

5.1 Riding instructions



WARNING

Avoid:

- engaging the brakes at a high speed as this involves a risk of skidding and overturning;
- passing over holes and tracks as this can cause you to lose your balance and overturn with the bicycle;
- forcing kerbs – use the ramps instead. If this, nevertheless, is necessary, get off the bicycle and pull the bicycle up or down over the edge. If you have a motorized version you can use the auxiliary motor's help function. See section "Use of the throttle". When using up- and down hills: Always ensure to cross these perpendicularly so that the rear wheels force the offset simultaneously, which will prevent the bicycle from tilting. This will eliminate the risk of falling over.



WARNING

Adapt your speed:

- when riding in rough terrain. The bicycle will behave differently in such conditions, which is why you should adjust your speed to avoid unpleasant and outright dangerous situations;
- in bends. If you go around a bend at too high a speed, you risk overturning;
- to the weather and other conditions. Riding on wet and slippery roads poses a particularly high risk, which is why you should ride carefully and at a reduced speed – in particular in curves and bends as well as when riding downhill.



WARNING

Note that:

- the bicycle is wide – watch out for curbstones, roadsides, chicanes, people and other obstacles.
- the bicycle can make undesired movements while you mount or dismount it. **ALWAYS** use the parking brake when you park the bicycle and, in particular, when you mount or dismount the bicycle.
- If you are also carrying luggage / wheelchair / walker, make sure that it is securely fastened. You can find the right accessory to ensure secure transportation and fastening of your bicycle in the section about accessories.

5.2 Before taking your bicycle out for a ride

Check daily, before each ride:

- ✓ That the bicycle is in a perfect condition;
- ✓ The tyre pressure;
- ✓ That the light and statutory reflectors are installed.
- ✓ The following brakes: Handbrake in front, handbrake at the back as well as foot brake (assuming the model has a foot brake);
- ✓ Parking brake
- ✓ That the handlebars are properly fastened;
- ✓ That the seat is properly fastened;
- ✓ That there is no gap in the wheels;
- ✓ That the chains are lubricated and adjusted;
- ✓ That the bicycle is fitted with the statutory reflectors;
- ✓ That the bicycle is fully charged (if it is an E-Bike / Pedelec).



6 SAFETY INSTRUCTIONS

6.1 Wear and tear of wheels and tyres

You should perform regular (weekly) checks of the bicycle's tyres. If you see any hair cracks starting to form on the side of the tyre, replace the tyre. New tyres can be ordered from PF mobility or your dealer. We recommend that you always use puncture-proof tyres. The bicycle is delivered by default with tyres with high puncture protection and reflective edges.

Also check the wheel rims for cracks or ruptures. Bicycles that ride on very rough / uneven terrain are more receptive to wear and tear.



Defective wheel rims can lead to accidents and should therefore be replaced immediately!!!

6.2 Warnings

Take off any loosely hanging clothes and put on something that fits snugly and cannot get caught in rotating parts such as wheels and chains before you mount your PF bicycle. . If the bicycle is equipped with a lap belt, it should also be ensured that this is unable to get caught in rotating parts when not in use.

Do not use your PF bicycle if any of its safety guards, e.g. wheel guards, chain guards or the guard over the rear axle are defective or missing.

Take extra care when adjusting the seat or armrests as inattention may cause you to jam your fingers. Only make adjustments when the bicycle is completely still.

7 SETTINGS AND ADJUSTMENT:

The following pages contain instructions for the daily adjustment options of the PF bicycle. Wherever you need to use tools, it is important after the adjustment to tighten all bolts, etc. you have loosened.

7.1 Handlebars:

Adjust the angle of the handlebars by loosening bolts "1" and then place the handlebars in the desired position. Tighten up bolts "1" with a torque of 10 N.m.



Adjust the height of the handlebars by loosening bolt "2" until the little plate lets loose of the cogs. Then you can change the height. Tighten back the bolt until the plate locks into the cogs.

7.2 Seat:

You can regulate the distance from the seat to the pedals by lifting release arm "1" underneath the seat frame. You will need to loosen the clamping lever "2" if you need to dismantle or adjust the seat vertically. When raising the seat height, you MUST fit the original spacer pipe to ensure that the seat remains at the required height (optional equipment).

There is a screw on the opposite side of the release arm that makes sure that the seat cannot slide off the rails. Check regularly that this screw is tight



Do not raise the seat without extension pipe.

- use special spacer / extension pipe for the seat if you need to raise the seat (optional equipment).

7.3 Brakes

All of our bicycles are fitted with at least 2 brakes. The left handbrake handle operates the V-brake on the front wheel, whereas the right handbrake handle operates the brake disc fitted to the differential gear on the rear side of the bicycle. The bicycle can also be fitted with a foot brake (gear hub) or a freewheel wherever a foot brake is not an option.

The parking brake is fitted to the handlebars. Turn it up to activate the brake. To disengage the brake, give the handle a gentle pull until the lever falls down the low mark.

The brakes need continuous adjustments. Turn the long adjusting screw marked in the picture counter-clockwise and fix the check nut farthest in towards the brake handle. Extensive adjustments of the V-brake should only be conducted by a professional.



7.4 Gear

Your PF bicycle is delivered by default with 7 gears made by Shimano.

Twist the rotating handle "1" with the thumb and index finger to switch gear. Keep the pedals still when you change gear while riding.

It is necessary to make subsequent adjustments of the gear. You can do this, as follows: set the rotating handle "1" to gear 4. Then adjust the gear with the adjusting screw "2" until the yellow dots "3" on the gear hub are parallel.



7.5 Chain adjustment

Front chain (A): Loosen the hex bolt on the left side with the 8-mm hex key (1). Turn the double gearwheel clockwise with the 17-mm combination wrench (1) to tighten the chain. Hold the bolt of the double gearwheel in position with the 17-mm combination wrench (1) to adjust the chain and then tighten the bolt securely to (1).

Middle chain (B) and back chain (C): Loosen the hub nuts and the brake lever's nut and screw. Loosen the counter nut of the adjusting screw using the 17-mm fork spanner (3). You can now adjust the medium and back chain with the adjusting screw and the chain adjusters. **Remember to tighten well after each adjustment!!!**

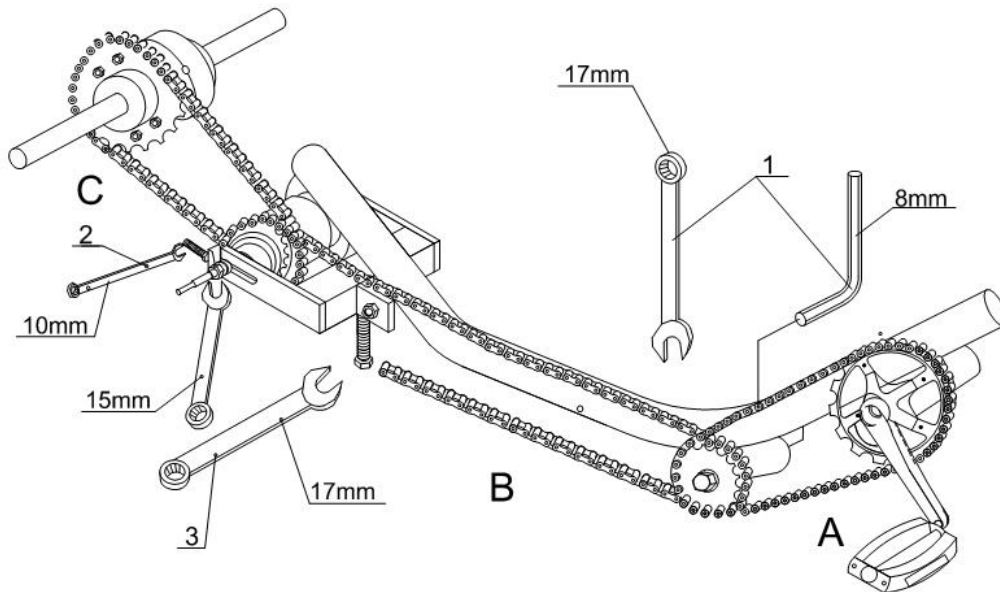

8 ELECTRICAL SYSTEM AND MOTOR

Peruse this chapter carefully if your bicycle is equipped with an auxiliary electric motor. Save these instructions and remember to bring them if you take the bicycles to other repairmen. Non-compliance with these instructions can lead to personal injuries or damage to the bicycle or its components.

PF mobility may not be held liable for any damage or loss resulting from failure to comply with these instructions.

8.1 Electric bicycle and the concept “pedelec”?

Electric bicycles from PF mobility are equipped with the so-called pedelec system. On a pedelec, the electric auxiliary motor is only activated when the pedals are pushed. A 'speed sensor' at the pedals detects when the pedals are pushed. The bicycle may now be started and the speed and force with which the bicycle is pushed is regulated in five auxiliary levels. Alternatively, the bicycle may be pushed forward by turning the throttle while simultaneously pedalling. See the more detailed description of both principles below.

The auxiliary motor of the bicycle is only active at speeds up to a maximum of 25 km/hour. However, your bicycle may be set to disconnect the auxiliary motor at a lower speed - see your order confirmation.

The throttle also works as start assistance or “walk assist”. This means that the bicycle may be started - without simultaneously pedalling – by turning the throttle, after which the bicycle starts and increases up to a maximum of 6 km/hour, after which the pedals must be pushed. This is a useful feature if, when starting, the pedal position is less optimal and/or if you need to push the bicycle while walking beside it. The current speed, both during the use of the walk assist function and, of course, during normal cycling, is displayed in large numbers in the middle of the screen:

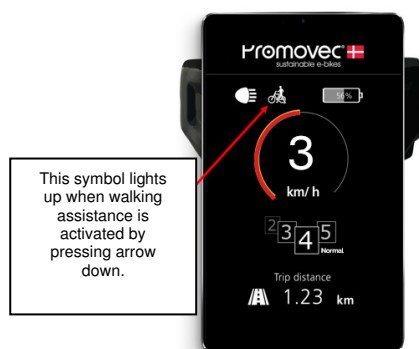

8.2 Safety instruction

Risk of breakdown of load-bearing parts.



WARNING

Any unusual noise as well as unintended reactions from the engine system may indicate a defect.

- If you experience this, contact the dealer immediately.

Hazard of fault or fire



WARNING

Defective electrical connections or cables can cause short circuits. This can cause electric faults or, in the worst case scenario, fire!

- Replace any ruined or defective electrical connections and components.

Hazard of unintended operation of the motor and other rotating parts



WARNING

The motor can be activated inadvertently if the electrical system remains "on" while your bicycle is undergoing maintenance. Clothes can get caught into the rotating parts and cause personal injuries.

- Always remove the battery from the bicycle before you start any work on the bicycle.

8.3 Hazards for special user groups

Children and adolescents are allowed to use electric bicycles on the public road network, but only under the supervision of an adult.

The bicycle should be parked out of the reach of children or persons who are not capable of handling the specified risks.

Riding an electric bicycle is different than riding an ordinary bicycle. This is why we recommend that you practise in a place without traffic before you ride in traffic.

8.4 Battery

A Li-Ion battery combines a low weight with a very high current capacity. This makes it rather compact and contributes to keeping the weight of the bicycle low.

Your PF bicycle comes with a "rear-rack" battery with 396Wh capacity as standard, but you can choose to purchase a larger battery with a capacity of 692 Wh.

"Rear Rack" battery



Only charge lithium-ion batteries using the provided charger. You can significantly increase the service life of the battery by ensuring proper recharging and preventing the battery from discharging completely. To prevent depletion and help you as owner of the bicycle, we have taken these factors into account in the enclosed charger. For the same reason, you may only use the charger to charge the battery of your bicycle.



WARNING

Fire hazard

Incorrect recharging of the Li-Ion battery may cause the battery or charger to heat substantially. This can cause a fire!

- Always use the accompanying charger when recharging the battery. The charger is NOT suited for outdoor use.
- Before you connect your charger to the mains, you must ensure that the mains voltage corresponds to the permitted voltage of the charger. The voltage is stated on the rating plate of the charger.
- Only charge the Li-Ion battery in a dry, non-flammable environment.

Mechanical damage to the Li-Ion battery or the charger can cause malfunction and short-circuit. In turn, this can cause fire.

- Any form of manipulation of the battery or charger is strictly forbidden.
- **Immediately** replace the battery if ruined and dispose of it safely, e.g. by handing it over to a municipal receiving station.



WARNING

Risk of electric shock

Chargers with defective cords or connectors can cause an electric shock.

- Never plug defective connectors or cables to the mains.
 - Immediately replace any defective components and cables.
 - Protect the charger against penetration of water and moisture. If water has penetrated into the charger, pull out the connector and have the charger inspected by a professional.
 - Condensation can form if the charger has been exposed to a sudden temperature increase. If this happens, you must wait until the charger has the same temperature as its surroundings before you connect the charger to the mains. Always store the charger wherever it is used.
- Only use the charger to charge the supplied Li-Ion battery. Other use is not permitted.

NOTE!

According to the manufacturer (see label on battery), any form of warranty will be waived if the battery is left uncharged for a period of more than one month! Therefore, please be aware of this - especially during the winter months when the bicycle is perhaps not used so often; otherwise, there is a risk that your warranty on the battery will be voided!

8.5 Charging the battery

Be sure to fully charge the battery before you use your bicycle for the first time. The battery can be charged while it is installed to the bicycle. The battery can also be detached and charged in a more appropriate location.

1. Open the dust cap and insert the charging plug.



The plug on the charging cable is a DC pin which is simply plugged in as it cannot be connected wrongly. However, always be careful and never use force when connecting the two.

2. Connect the charger to an electrical outlet.
3. While charging the LED is illuminated in red. When charging is complete, the LED on the left turns green and the power may be switched off.

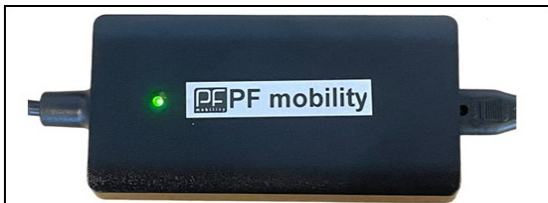

When connected to an electrical outlet and when charging is complete the LED will turn green.

While charging, the LED will be red.

Battery on and off:

If you remove the battery to charge it, then please observe the procedure:

- Slide the battery onto the battery rail in the rear carrier.

Ensure that the battery slides in straight.

- The battery locks automatically when inserted into the rail.

- The key can be removed from the battery.

Store the key in a safe place!

- Unlock the battery to release the handle and remove it by pulling the handle.

*Note

- Do not pull the handle when the battery is locked to the bike.

The battery can function as a power bank using the USB port on the opposite side of the charging socket.

The battery can be removed when the handle is flipped out.





In order not to risk breaking the slide part of the battery holder, make sure that the battery is completely free of this before you lift it up!



The charging time is approx. 6 hours for full charging of the 396 Wh battery and approx. 9.5 hours for the 692 Wh version. The charger then switches to maintenance charging, which ensures that the battery does not discharge. If the battery is not fully charged, the bicycle's range will be reduced.

Do not charge the battery at temperatures below 10 °C or over 35°C, in direct sunlight, next to radiators and similar. When the temperature outside is below 0°C, we recommend that you charge your battery in a heated room.

If you do not use the bicycle for long periods of time, you should remove and store the battery in a dry, frost-proof place. Make sure to fully charge the battery before storage and again before you are about to use the bicycle.



Every time you install the battery on the bicycle, make sure that the casing is locked.

NEVER LEAVE THE BATTERY UNCHARGED FOR A PERIOD OF MORE THAN ONE MONTH. THIS MAY RESULT IN A VOID OF YOUR WARRANTY IF NOT COMPLIED WITH!

9 ACCESSORIES

You can buy additional accessories and equipment for your PF bicycle. Get in touch with your dealer or PF mobility if you want to know more about your options.

Foot supports:



Foot plate 5 sizes



Pedal w/ toe clip



Pedal w/ toe clip and side support



Foot plate w/ calf support



Pedal w/ straps



Training pedal



Pedal extender

Seats and belts:



Arm rest



Swivel seat



Seat w/ inclination



Harness



H-harness w/ holder



H-harness w/ holder and neck support

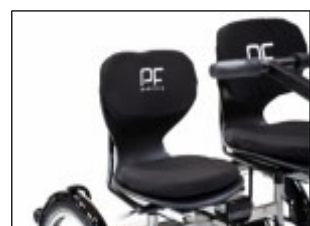

Junior seat



Seat cover / rain cover

Other accessories:



Extra thread basket at the back



Top box



Holder for walker



Holder for walking stick



Bike cover

10 MAINTAINING YOUR BICYCLE

10.1 Important



WARNING – Risk of malfunction in the event of incorrect or missing maintenance.

Incorrect or missing maintenance of an electrically operated bicycle can cause faults and damage to electrical and mechanical components! In this worst case scenario, this can cause you to crash and suffer a personal injury.

- The electrical system may only be maintained by a professional.



WARNING

Hazard of unintended operation of the motor and other rotating parts

The motor can be activated inadvertently if the electrical system remains "on" while your bicycle is undergoing maintenance. Clothes, etc. can get caught into the rotating parts and cause personal injuries.

- Always remove the battery from the bicycle before you start any work on the bicycle.

Provided that they are both used as described and intended in this Manual, the electric motor and the battery are maintenance-free.

Have a professional conduct a safety check of the following items every 1,000 km:

- Intact and secure fastening of cables and components
- Review and testing of the complete electrical system.
- Safe use of the battery

10.2 Daily check

As mentioned above you should before taking your bicycle for a ride check:

- Brakes and parking brake
- Chains
- Tyres and wheel rims
- Light and reflectors
- Battery condition

Your bicycle is equipped with a **parking brake** that is designed to prevent the bicycle from making any undesired movements during parking. This is particularly important when you mount or dismount the bicycle. You should test the parking brake and make sure that it operates adequately every day. We recommend that you always use the parking brake when you get off the bicycle. Adjust the brake when it does not operate adequately or as intended. For adjustments, see Section 3.3 *Adjustments*.



Test the **foot brake and handbrakes** daily to ensure that you can bring the bicycle to a halt quickly and safely.

Note that you can experience longer braking distance in humid weather.

Chain

To be able to use your bicycle safely and without any risk, you must check that the chain is properly adjusted and lubricated.

For the proper adjustment of brakes or chains, refer to a professional – see also Section 3.3 *Adjustments*.

Tyres and wheel rims



We recommend that you check daily – or at least weekly – that the tyres are properly inflated and not worn. The correct tyre pressure is 4-5 bar.

Since the bicycle uses rim brakes, you should also check the wheel rim of the front wheel for wear and tear and cracks.

Light and reflectors

Check that the bicycle's reflectors are whole and clean and that all statutory reflectors are fitted to the bicycle. White in front, red at the back, yellow on the pedals and white again on the tyres (standard equipment) or yellow on the spokes.

If you ride the bicycle at night, before you mount, you must check that the **light** of your bicycle works.



Before you leave home, you must also check that the **battery** is charged – check battery level on the screen – see page 23

Periodic maintenance – and first service check!



In order to be in a good and safe mechanical condition, your bicycle is in need of periodic maintenance. The maintenance inspection should cover, as a minimum:

- Brakes
- Tyres and wheel rims
- All moving parts and bearings, crank, pedals, etc. (clearance and mobility)
- Chain
- Gear
- Electrical system and battery
- Frame
- Tightening of bolts, screws and nuts

The inspection should be conducted by a professional. We recommend a maintenance inspection every 1,000 km or at least once a year. You can buy an inspection from PF mobility through your sales consultant.

Service check



A service check must be carried out three months after the purchase of each new bicycle

The gear, wires, bolts, chains, spokes, etc. of each new bicycle need some time to "settle", which is why it is necessary to check carefully and tighten / adjust individual parts.

This inspection must be conducted by a professional!

Lack of maintenance / service inspection can cause hazardous incidents and void the warranty.

10.3 Cleaning

Important information for electric bicycles.



- Remove the battery before you start cleaning your bicycle.

You can clean the bicycle with a moist – but not wet – soft cloth and water with a bit of detergent added, e.g. bicycle shampoo or similar.



Never use high-pressure cleaner or water jet.

Do not use a hot water or steam cleaner, a high-pressure cleaner or strong water jet / spray to clean your bicycle. If water penetrates inside, it can ruin the electrical components, motor bearings and other moving parts of your bicycle.



10.4 Lubrication



Clean and lubricate the chain of your bicycle, as needed. The more often you use the bicycle, the more often the chain will be in need of lubrication. Riding in humid and wet weather increases the need for lubrication. We recommend that the chain be lubricated at least once a month and more often in the winter season. You can buy a suitable detergent and lubricant from your bicycle professional.

As a rule, none of the other moving parts is in need of regular lubrication, but should only be inspected periodically by a professional and lubricated, as needed.

10.5 Tightening of bolts, etc.



It is important to ensure that all critical components of the bicycle are attached properly. These parts need to be tightened with the proper torque. The required tightening force is stated in the following table:

Component:	Torque (+/- 5 Nm)
Wheel nut, front	45 Nm
Wheel nut, back	45 Nm
Stem – height	Indicated on the stem
Exocentric disc (front sprocket)	70 Nm
Rear beam	35 Nm
Rear axle – bearing	20 Nm
Saddle	40 Nm

10.6 Repair and replacement

To guarantee your safety, PF mobility recommends that you only use original spare parts. This will also allow you to benefit the most from the use of the bicycle. PF mobility has spare parts on stock and can deliver parts from one day to another.

Contact your dealer or PF mobility for assistance and delivery of parts as well as replacement, if relevant.

11

DISPOSAL



Do not dispose of electronic and electrical components as ordinary household waste as this is prohibited by law. You as a user should therefore make sure that all electronic and electrical components are disposed of via an approved public waste management scheme, through a dealer or by PF mobility.

By complying with this and recycling or using an approved return scheme, you will contribute to making a real difference and help protect the environment.

Dispose of electrical components in accordance with the applicable national legislation.

For advice about disposal, you can contact the local authorities or your dealer.

12

WARRANTY AND OBLIGATIONS

All of PF's bicycles sold to individuals come with 2 years of warranty; cf. the provisions of the Danish Sale of Goods Act. In addition, there is 5-year warranty for the frame provided that the product has been used as described in this Manual.

Assuming ordinary use and periodic service, the expected service life of this bicycle is 5 to 10 years.

PF mobility may not be held liable for any damage to the bicycle itself or other objects or for injuries to people:

- caused by the abnormal use of the bicycle, **e.g.** in races or for riding in rugged terrain, etc.;
- if the user has disregarded or failed to comply with the instructions in this Manual ;
- caused by inadvertent use of the PF bicycle;
- if there are any alterations to the structure of the bicycle without the producer's written consent;
- if the bicycle has been exposed to abnormal wear and tear or an overload;
- if the bicycle is not maintained normally or is exposed to extreme corrosion.



14. MANUFACTURER'S BATTERY HANDLING INSTRUCTIONS

WARNING!

~ READ INSTRUCTIONS

This product is a powerful high-performance Lithium-Ion battery. Make sure you read and follow the below instructions regarding handling, charging, storing, and cleaning. Not following these instructions may have serious consequences and can result in a fire, which may seriously injure you and/or other people. Save these instructions for future reference.

1. Only use the type of battery that is specifically designed for use with your product. The same applies to the charger and charger cables.
2. Charge the battery before use. Make sure to read the charger's manual for the proper charging method. Always follow the charging instructions when charging the battery.
3. For safety reasons, the battery should be charged in a room equipped with a smoke detector.
4. Do not place the charger or battery near flammable materials. Ensure that the battery and charger are placed on a fireproof surface before charging.
5. If the battery terminals are dirty, use a dry cloth to clean them before use. Otherwise, there may be power or charging failures due to poor connection with the instrument.
6. Do not allow metallic objects such as keys, coins, or screws, come in contact with the battery's charging socket, or the charger's charging connector, which could cause a short-circuit.
7. Be careful not to pierce the battery with a sharp object.
8. Always keep the battery and charger out of reach of children. They are not toys.
9. Do not allow children to replace batteries without adult supervision.
10. People with reduced physical, sensory, or mental abilities, as well as those with limited experience or knowledge, should be supervised or provided with training in the use of batteries/chargers.
11. Do not use or charge a damaged battery (cracked, chipped, or leaking). Similarly, avoid using a damaged charger or wire.
12. Never open, disassemble, or modify the battery or charger.
13. Keep the battery dry and clean.
14. Water inside a battery or charger can cause a short circuit and fire. Do not pressure-wash your battery or charger. Do not submerge them in water or leave them out in the rain or snow.
15. Do not clean the battery with solvent materials (i.e., dilution, alcohol, oil, anti-corrosive) or chemicals that impact surfaces (i.e. detergents).
16. The battery must not be heated, exposed to fire, short-circuited, punctured, subjected to severe impacts, twisted, or otherwise mishandled. Additionally, avoid storing it close to heating devices, in direct sunlight or at temperatures exceeding 60°C.

17. Store the battery in dry conditions away from open flames and food.
18. Batteries must be disposed of in accordance with local laws and regulations.
19. Temperatures above 70°C/158°F may result in battery leakage and rupture.
20. Seek medical aid in case of symptoms obviously caused by respiration or swallowing of the combustions gasses or contact with skin or eyes
21. Battery liquid can cause skin irritation and burns. If you come in contact with battery fluid, immediately flush with water and seek medical assistance, if needed.
22. If battery fluid comes into contact with the eye: Flush the eye gently with plenty of water (at least 15 min). Shield unaffected eye. Seek for medical assistance.
23. If transported separately, this product must considered as dangerous goods. Professional transport requires special handling and safety instructions.

Operating temperature	
-20°C - +60°C or -4°F - +140°F	
Charging temperature	
0°C - +50°C or +32°F - +122°F	
Storage temperature	
≤ 1 month	-20°C - +60°C or -4°F - +140°F
≤ 3 months	-20°C - +40°C or -4°F - +140°F
≤ Year	-20°C - +25°C or -4°F - +77°F

Notes:

- Charge the battery at least every 30 days.
- The battery has to be recharged every 30 days to ensure its performance.
- Rechargeable battery systems have the greatest performance when kept and used at normal room temperature (approx.. 20°C/ 68°F)
- Avoid big temperature changes.

In case of fire:

- Cautiously remove other batteries if possible.
- Evacuate all persons from immediate area of fire.
- Submerge the battery in plenty of cold water (min. 10 times pack weight).
- After inhalation: Leave area immediately. Seek for fresh air and medical assistance
- in case of symptoms obviously caused by respiration of combustion gasses.

Extinguishing media

- Water/CO2

Display Graphic D400+

QUICK START



TABLE OF CONTENTS

DISPLAY OVERVIEW	31
MAIN MENU	35
INFO	34
CLOCK.....	35
BIKE SETTINGS	36
DISPLAY	38
DRIVING MODE	39
CRUISE CONTROL.....	41
TROUBLESHOOTING.....	42

QUICK START

The system has two assist functions options. The assist function will show in the display, when selected:

- Assist level 1–5. Select by using the "Up" and "Down" buttons
- "Walk-Assist" function is activated by holding the minus button or by using the throttle without pedaling. When "Walk assist" is activated then the bike travels with 6 km/h.

"Walk-Assist" is usable if you need to pull the bike up a hill.

Note! "Walk-Assist" is not available on bikes equipped with center motor and footbrake

DISPLAY OVERVIEW

The display is accessed with 5 buttons and the throttle from the left side of the handlebar. The display is mounted on the stem. Read this guide for more information about display functionality and bike information.



Light

Light symbol is active when the front light is on



"Walk Assist"

The symbol is active when you press and hold the "Down" button.

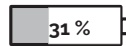

Battery level

Indicates the remaining capacity in percent.



Power consumption and speed

The red circle indicates power consumption. The Speed is indicated with km/h or mp/h

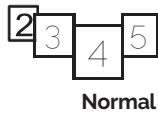

Assist level

The numbers indicate the assist level. Use "Up" or "Down" to change it. "Driving Mode" (normal) see driving modes on page 39.



Info area

Displays speed and trip trackers. Switch with a short press on the "Menu" button



LIGHT



Lights On/Off

UP



Assist level Up and navigate in menu

MENU



Change info and select in menus

DOWN



Assist level Down and navigate in menu



ON/OFF

1 DISPLAY NAVIGATION



"Menu" button
Press and hold to
go to "MAIN"



Move the marker with
UP or DOWN buttons



Select with "Menu"



Select arrow left in
the menu to go one
level up

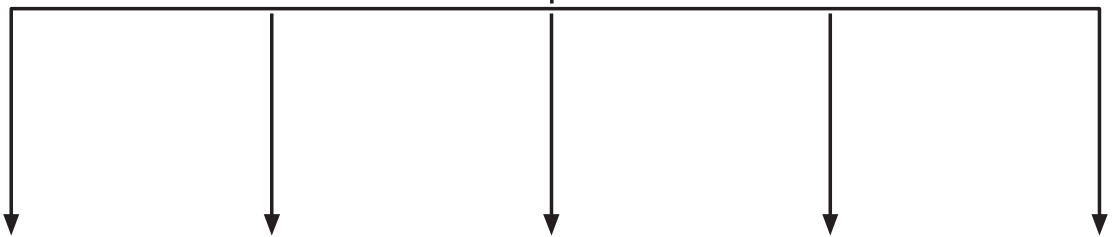

INFO	CLOCK	BIKE SETTINGS	DISPLAY	DRIVING MODE
<ul style="list-style-type: none"> BIKE Total Distance Trip Distance Trip Time Average Speed Max Speed BATTERY Battery State of Charge State of Health SERVICE Controller FW Version Display FW Error Code Log 	<ul style="list-style-type: none"> ADJUST Date Time CLOCK FORMAT HH:MM AM/PM HH:MM 	<ul style="list-style-type: none"> Wheel Size Default Level Assist Level 1 Assist Level 2 Assist Level 3 Assist Level 4 Assist Level 5 Retain Bike Light Manual Always On Auto-Off Time 5 Min 30 Min 60 Min 	<ul style="list-style-type: none"> UNITS Imperial Metric BACK LIGHT Day Night INFO AREA Trip Dist. Trip Time Total Dist. Remaining Dist. Clock Bike Power 	<ul style="list-style-type: none"> (Pedal speed system) Speed ECO Set distance (Pedal torque system) Normal Torque Set distance

INFO

In "BIKE" menu TRIP DISTANCE" and "TRIP TIME" counters can be set to reset after:

- Power off
- 1 hour
- 4 hours
- Daily
- Manual

Speed values in the BIKE menu are ressetable. TOTAL DISTANCE is NOT ressetable. BATTERY and SERVICE menu includes information about the battery state of health, firmware version and error codes.

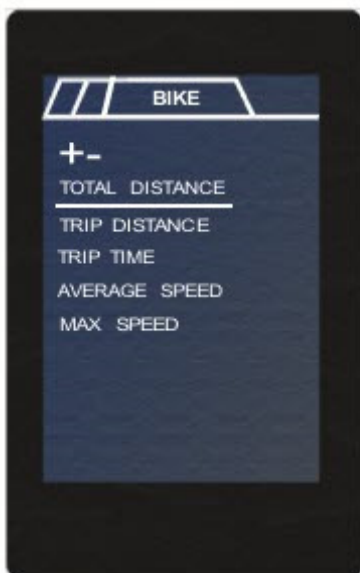
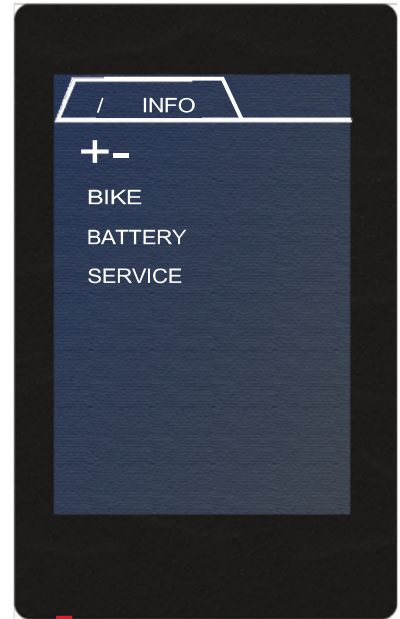

CLOCK



Move the marker with UP or DOWN buttons.

Select with "Menu"

Select arrow left in the menu to go 1 level up

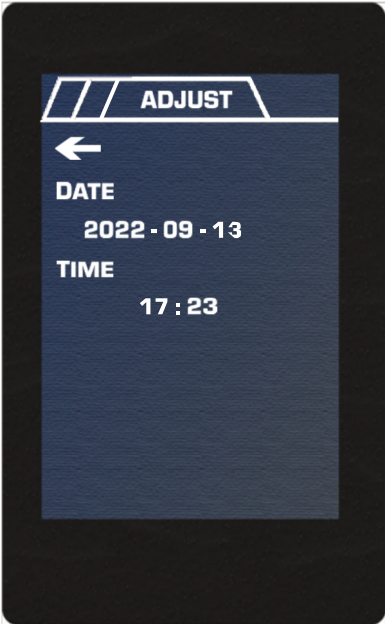

ADJUST

Select DATE or TIME

1. Adjust the values with "Up" or "DOWN"
- 2.....accept with "MENU" and move to the next value

**CLOCK
FORMAT**

Move the marker to the time format that should be displayed.
Select with "Menu"

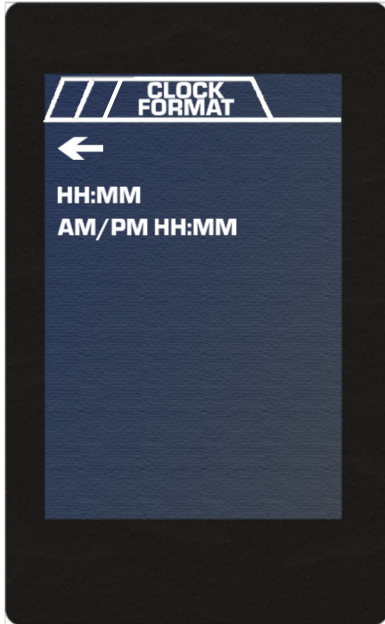

BIKE SETTINGS

In "BIKE SETTINGS" it possible to customize the following settings when the e-bike is turned ON:

- Start up in assist level 1-5
- Light on
- Turn OFF timer, set to 5, 30 or 60 minutes

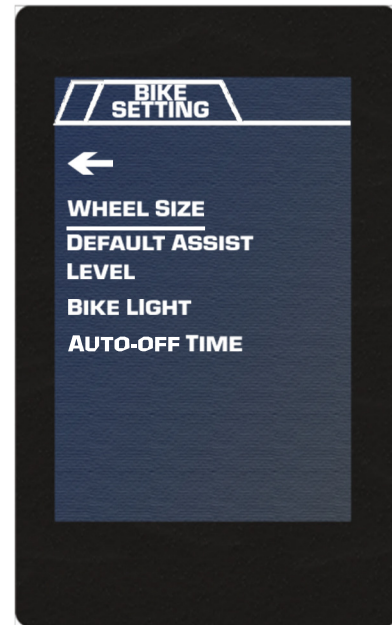

ETRTO (European Tyre and Rim Technical Organisation)

ETRTO	REIFEN	LÄNGE
47-305	16x1.75	1250
47-406	20x1.75	1550
55-406	20x2.15	1610
47-507	24x1.75	1850

Wheel size adjustment. The wheel size value can be found on the tire sidewall – see above table 1



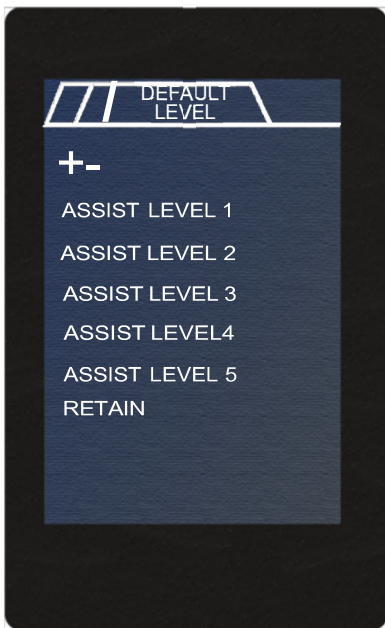

Set the e-bike to start up in assist level 1–5 or to retain the level when the bike is powered off.

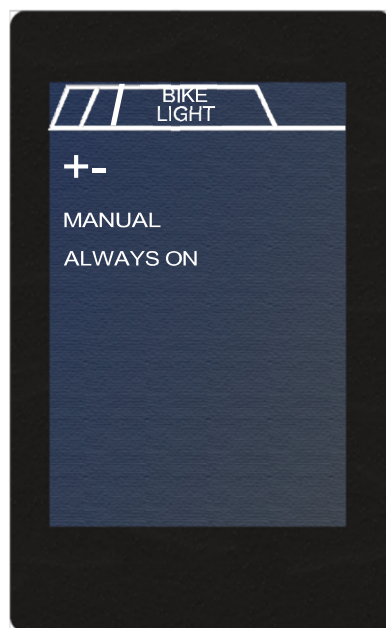

Set the light to be controlled manually or always on when the e-bike is powered ON



Set the light to be controlled manually or always on when the e-bike is powered ON

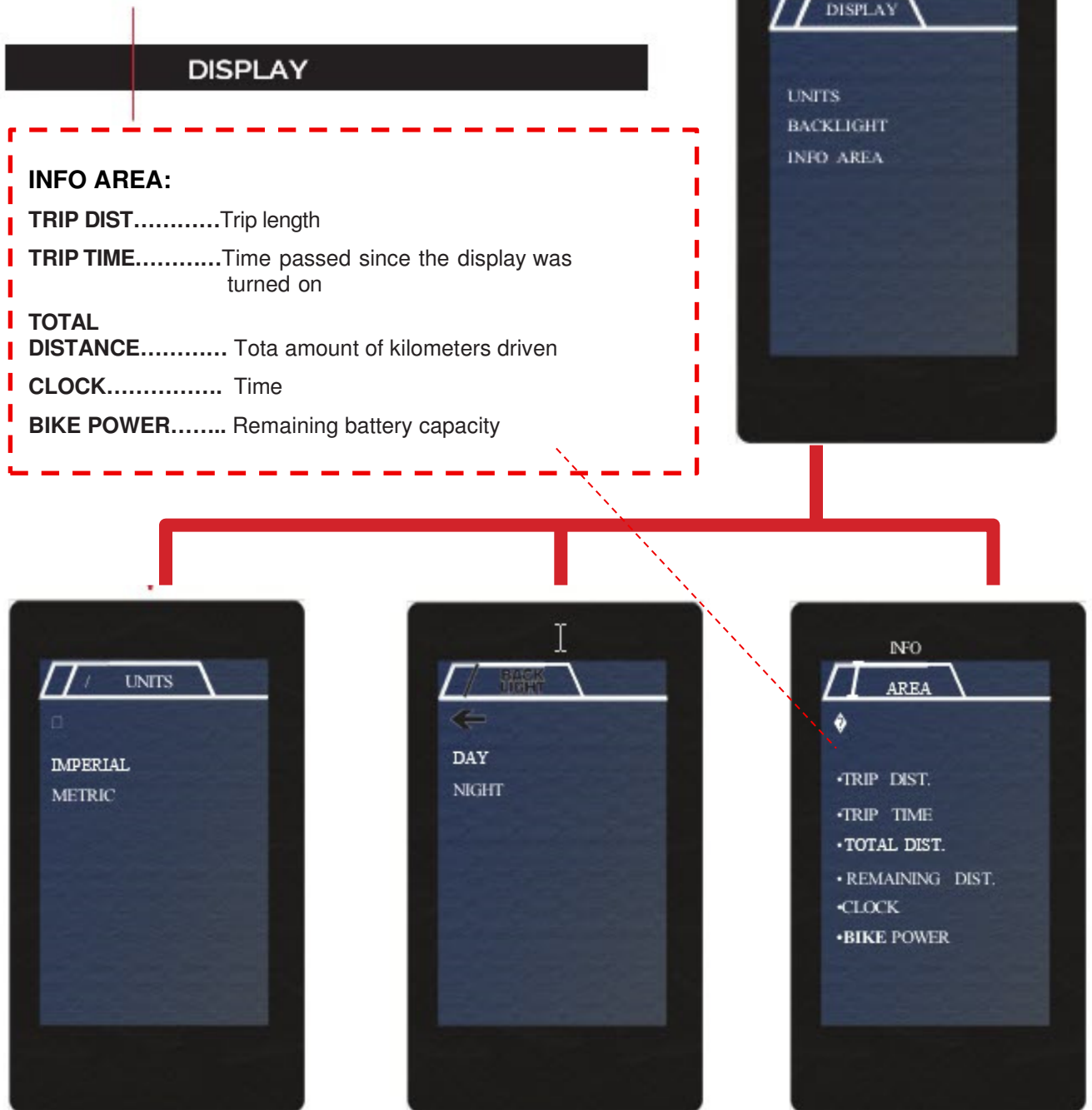

Select Imperial for inches and metric for centimeters.

Set the backlight strength for day and night. When the front light is on, "NIGHT" setting is on.

Select the values that should be displayed in the display info area. A dot indicates the value is active.

DRIVING MODE

Depending on the electrical system installed on your bike, there are 2 different system options. Each system includes 3 different assist types:

Pedal speed sensor system

- Speed mode.
- ECO mode.
- Set distance.

Pedal torque sensor system

- Normal mode.
- Torque mode.
- Set distance.

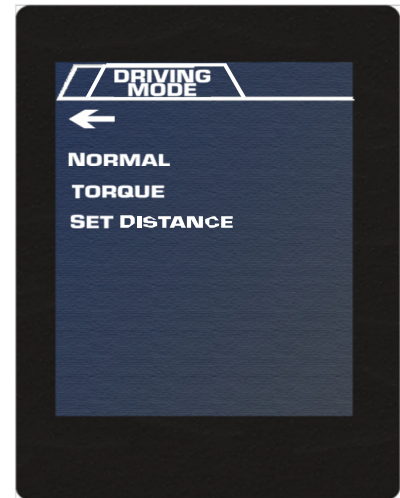

SPEED MODE

At a given "Assist level" the system will supply full driving force up and to the selected speed level

Usability

- Smooth ride

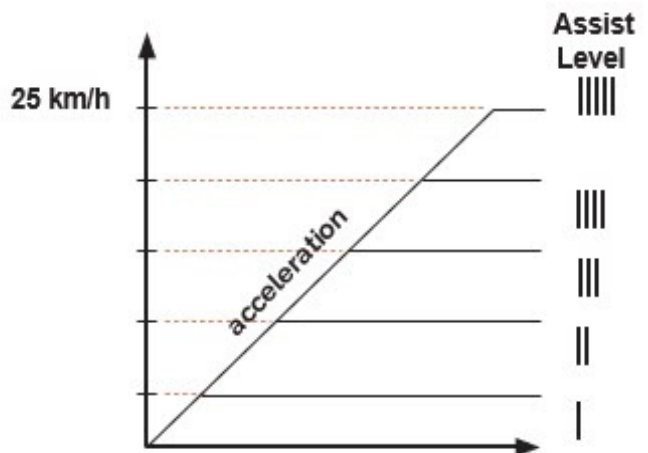

NORMAL + ECO MODE

At a given "Assist level" the system will supply a specified amount of driving force between 0–25 km/h.

Usability:

- Variable speed
- Relaxed ride

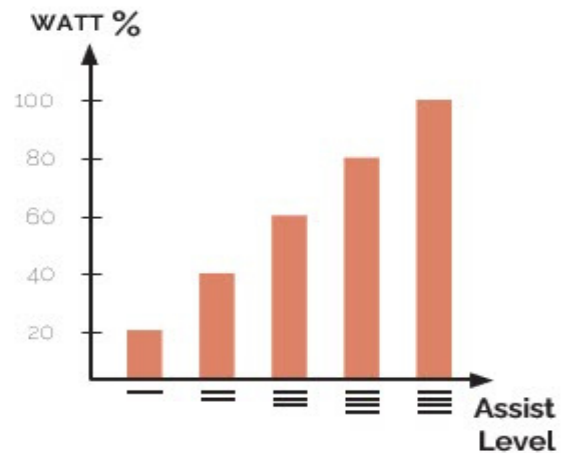

TORQUE MODE

The system provides driving force to the bike according to the amount of force the user added to the pedals. At assist level 1 the user will need to provide more propulsion than at level 5 to reach the same speed.

Note: Available on center motors with torque sensor only. Selecting higher gears enables the user to provide propulsion to the bike easier.

Usability:

- Variable speed
- More usability

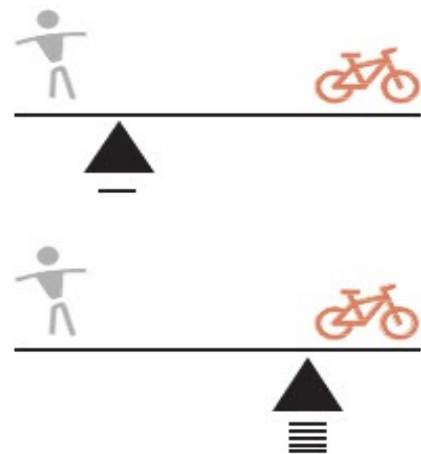

TAKE ME HOME (SET DISTANCE)

By setting a distance the system will manage power consumption and motor assistance for the entire ride ensuring the entered distance will be reached.

Usability

When trip length exceeds battery capacity.

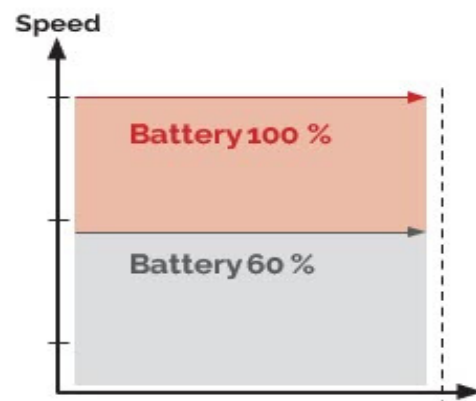

CRUISE CONTROL

Activate Cruise Control with the throttle and "MENU" button.

Activate the throttle while pedalling

Press "MENU" when the e-bike drives the speed you want to retain

The e-bike will maintain the set speed while pedaling. The display will read 0-100% as long as cruise control is active.

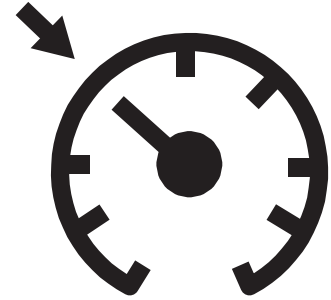

TROUBLESHOOTING

Errors are displayed, with a code and a description in the display info area. If an error is displayed then it is a signal about an error in the electrical system. A restart of the system is required when an error has been remedied.

ERROR CODE	MEANING	SOLUTION
1	Motor error.	Check motor connection** Contact retailer.
2	Controller error.	Contact retailer.
3	Throttle error.	Reset the throttle to start Check the display connector** Contact your retailer
4	Low voltage error.	Recharge the battery
5	Brake sensor error.	Reset the handbrake to start position. Check the light connection for moisture.** Contact retailer.
5	Brake/Shift Sensor error. Only with centermotor.	Reset the handbrake to start position. Check the light and shift sensor connection.** Contact retailer.
6	Speed sensor error.	Check the distance from the magnet to the sensor. Check the speed sensor connection.** Contact your retailer.
7	Battery malfunction.	Contact your retailer.
8	System overload.	Check connections.** Restart the system Contact your retailer.
9	Communication error.	Check connections** Contact your dealer.

ERROR CODE	MEANING	SOLUTION
10	High voltage error.	Contact your retailer.
11	Display error.	Check the display connection. ** Contact your dealer.
12	Temperature error.	Reduce the load. Check connections.** Restart the system or contact your dealer.
13	Only center motors with torque sensor.	Contact retailer.

*Check the wire connections are connected, free from water and the pins are not bent or damaged.